

# NIMH - TECHNICAL DATA SHEET - MODEL ESP2000AAH

TECHNICAL DATA SHEET

## Battery General Specification :

- Model** - ESP2000AAS  
**Chemical Material** - Nickel Metal Hydride.  
**Description** - 1.2v Rechargeable battery  
 AA size with Pip top.

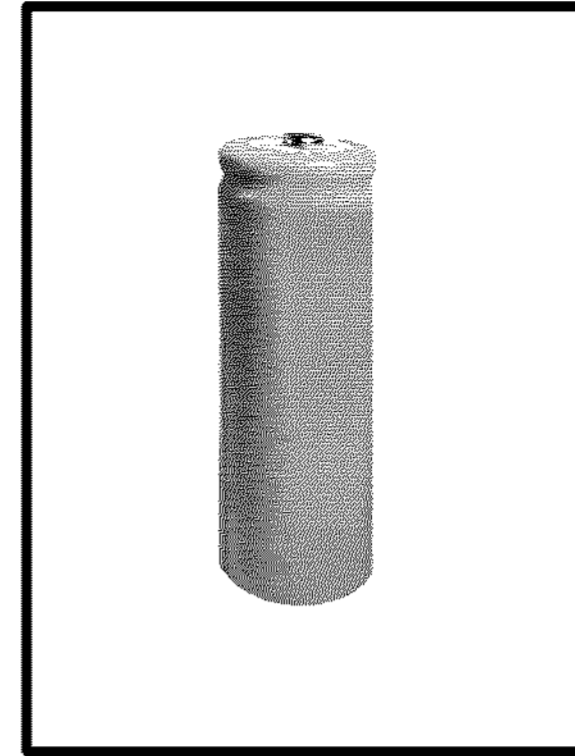

### Discharging:

#### (A) Discharge current.

- 1/ Discharged at 0.2CA, Provide 80% at EPV 1.2V 98% of nominal capacity at EPV 1.1V.
- 2/ Discharged at 0.5CA, Provide 70% at EPV 1.2V 95% of nominal capacity at EPV 1.1V.
- 3/ Discharged at 1CA, Provide 60% at EPV 1.2V 93% of nominal capacity at EPV 1.1V.
- 4/ Discharged continuously at 1C, for 2 hours, No explosion or leakage.

#### (B) Capacity and Cycle ( 500 to 800 cycles)

- Charge at 0.1C, discharge at 0.2C; 100% nominal capacity.  
 Charge at 1C, discharge at 1C; minimum 95% nominal capacity.

## Physical and Electrical Specifications.

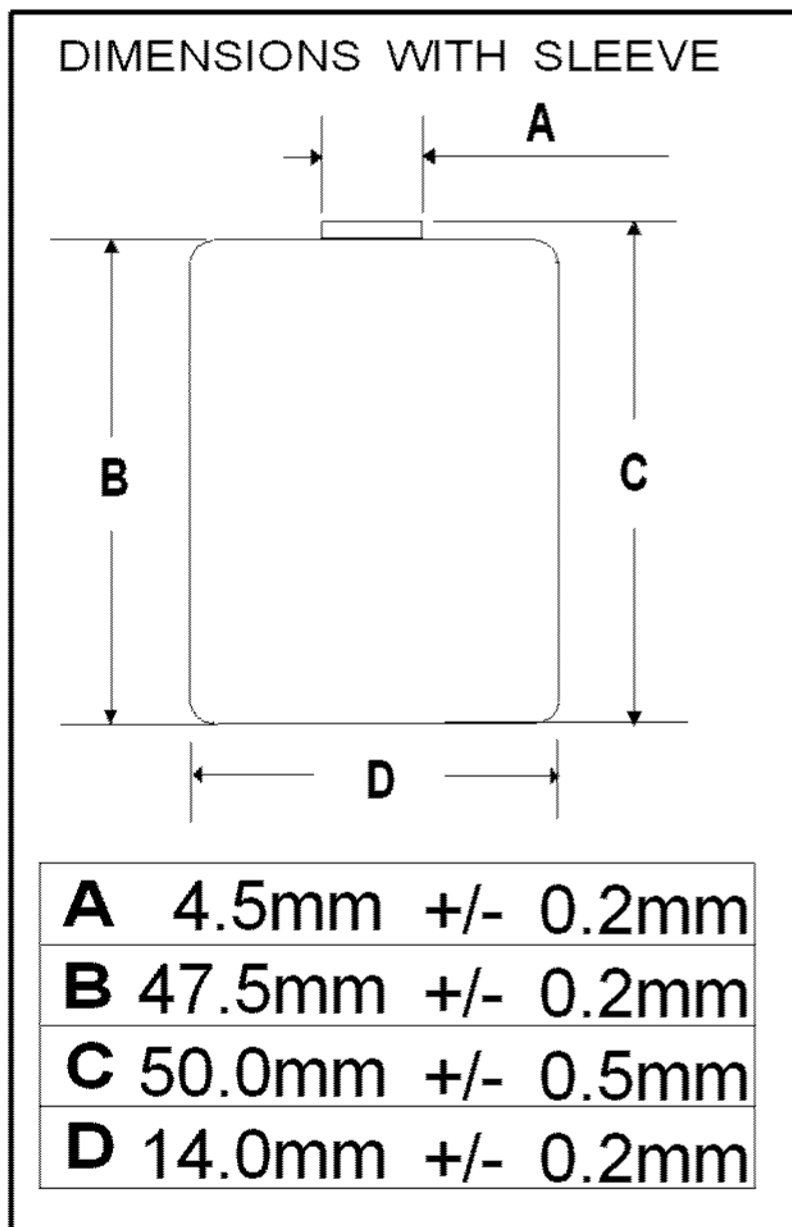

Nominal Voltage		1.2v	
Typical Capacity		2000mAh	
Weight		24g	
Internal resistance.		20mΩ	
Charge	Standard	200mA x 15.0hrs	
	Quick	555mA x 4.5hrs	
	Rapid	1050mA x 2.4hrs	
Discharge	200mA	64min	
	400mA	60min	
	2000mA	55min	
Ambient temperature	Charge	Standard	0 <sup>0</sup> to 45 <sup>0</sup> C
		Quick	0 <sup>0</sup> to 40 <sup>0</sup> C
	Discharge		-20 <sup>0</sup> to 65 <sup>0</sup> C
	Storage		-20 <sup>0</sup> to 45 <sup>0</sup> C

### Discharge Temperature at 0.2CA

- 1/ At 20<sup>0</sup>C, 100% nominal capacity.
- 2/ At 0<sup>0</sup>C, 90% nominal capacity.
- 3/ At 60<sup>0</sup>C, Or -20<sup>0</sup>C, 85% nominal capacity.
- 4/ Charge retention for 30 days at 20<sup>0</sup>C, cell can provide 70% nominal capacity discharged at 0.2CA.

**CELLS MANUFACTURED TO GB/T19001:2000 - ISO9000/9001: 2000 STANDARD & CONFORMITY**

Cell & Battery specifications are subject to modifications without prior notice. All the above information is generally descriptive and is not intended as a guarantee or warranty.

**ESP** SPECIAL BATTERIES LTD  
 565 Uppingham Rd  
 Leicester. LE5 6QA  
 England.

Tel 0116 2413796  
 Fax 0116 2416519  
 Email - info@espspecialbatteries.co.uk

ESP2000AAH